

BY	CHK	REVISION RECORD MODIFICATIONS	DATE	REV.
ALLEN		RELEASE TO PRODUCTION	2007,9,3	1.0

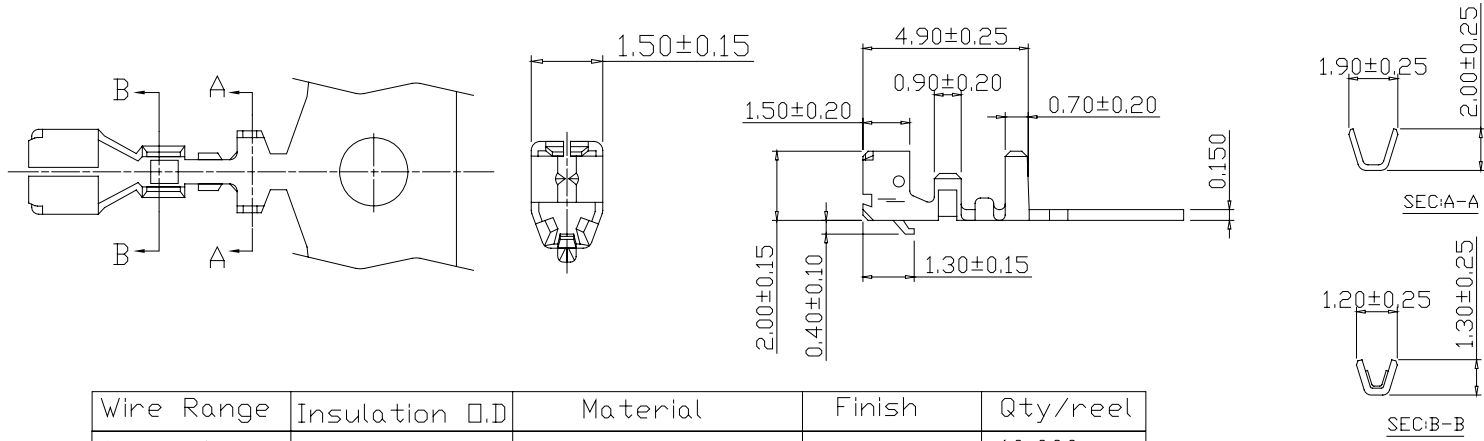

Wire Range	Insulation \square .D	Material	Finish	Qty/reel
AWG#24-#30	1.40mm(max)	Phosphor Bronze	Tin-plated	10,000pcs

PartNo.:2002-TL

SPECIFICATIONS
 Current Rating: 2A AC,DC
 Voltage Rating: 125V AC,DC
 Temperature Range: -25°C ~ +85°C
 Contact Resistance: 20m Ω Max
 Insulation Resistance: 1000m Ω Min
 Withstanding Voltage: 800V AC/minute
 Pin Material: Brass/Tin-Plated
 Material: Nylon 66, UL94V-0
 Color: Natural(White)

PART NO.	Dimensions	
	A	B
2002H-02W-L	2.00	4.90
2002H-03W-L	4.00	6.90
2002H-04W-L	6.00	8.90
2002H-05W-L	8.00	10.90
2002H-06W-L	10.00	12.90
2002H-07W-L	12.00	14.90
2002H-08W-L	14.00	16.90
2002H-09W-L	16.00	18.90
2002H-10W-L	18.00	20.90
2002H-11W-L	20.00	22.90
2002H-12W-L	22.00	24.90
2002H-13W-L	24.00	26.90
2002H-14W-L	26.00	28.90
2002H-15W-L	28.00	30.90

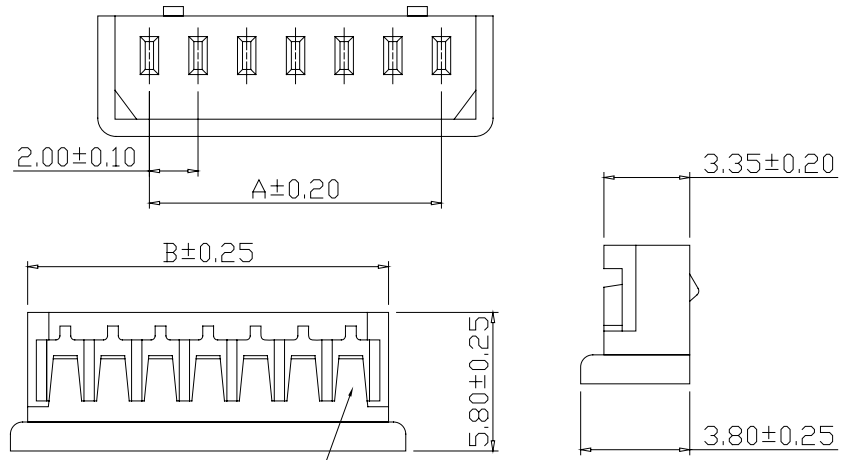

PartNo.:2002H-XXW-L

APPRO	CHECK	DRAWN	PART NO.	PartNo.:2002-TL		
			ITEM NO.			
			DRAW NO.			
			UNIT	mm	SCALE	no
			TOLER		NO.	

DESCRIPTION

